

## RHM03

### Versatile Coriolis Mass Flowmeter for Low Flow Applications

#### Features

- Standard pressure ratings up to 1067 bar (15475 psi)
- Temperature ratings from -196 to 350°C (-320 to 662°F)
- Mass flow uncertainty down to 0.10%
- Repeatability better than 0.05%
- Typical measuring ranges between 0.05 and 5 kg/min
- Accurately measure low flow rates down to 38 g/min
- Unique robust torsion driven oscillation system
- Process connection customization available
- Ultra compact design with minimal footprint
- Approved for use in hazardous areas
- Stainless steel case
- Removable connection manifold version available for easy and efficient maintenance
- Remote and compact transmitter versions available

#### Applications

Typical applications include:

- General Flow Control
- High Pressure Gas Dispensing
- Additive Dosing
- Mixing and Batching
- Chemical Injection
- Package and Container Filling

#### Benefits

- Torsion oscillator design assures a stable and drift free measurement with excellent signal to noise ratios
- Resilient to external noise and vibration
- Insensitive to pipe pressure changes
- Robust tube wall thickness provides increased operational safety in abrasive applications
- Long sensor life guaranteed due to low mechanical stresses in the meter mechanism
- No moving parts to wear or fail

## RHM03 General Specifications

<b>Nominal Max Flow Range:</b>	Parallel/dual path measurement tube versions: 5 kg/min (11 lb/min) Serial/single path measurement tube versions: 2.5 kg/min (5.5 lb/min)
<b>Temperature Range:</b>	5 temperature range options cover temperatures from -196°C to 350°C (-320°F to 662°F)
<b>Pressure Ratings:</b>	Dependent upon material
<b>Electrical Connection:</b>	Cable entry M25 x 1.5 (standard) M20 x 1.5, ½" NPT, ¾" NPT (optional) Max cable length to remote RHE transmitter 100m (330 ft)
<b>Sensor Housing Materials:</b>	1.4301 / 304 stainless steel (standard), 1.4571 / 316Ti stainless steel (optional) Epoxy coated aluminium electrical box (standard), 1.4571 / 316Ti stainless steel (optional)
<b>Enclosure Type:</b>	Protection class IP 65. IP 66 / NEMA 4X (optional)
<b>Material of Wetted Parts:</b>	Sensors are available in a variety of standard and custom materials to suit a wide range of pressure and chemical compatibility requirements. See the pressure ratings listing in this document for further details
<b>Finishes:</b>	ANSI flange finish: AARH 125 to 250 µin, Ra 3.2 to 6.3 µm
<b>Certifications and Approvals:</b>	ATEX approval Zone 0: Ex II 1 G Ex ia IIC T1-T6 Ga ATEX rating Zone 2: Ex II 3 G Ex nA IIC T1-T6 Gc CSA USA-Canada, Class I, Div. 1, Groups A, B, C, D PED according to 97/23/EC Art.3 (3) Sound Engineering Practice (SEP)
<b>Documentation:</b>	All sensors are supplied with a traceable calibration certificate. Optional documentation items available: - Traceable material certificates - Certificates of origin and conformity - Welding - NACE - Quality - Production and manufacturing procedures Other documentation to client requirements available
<b>Proof Testing:</b>	Hydrotest, dye penetrant, x-ray, PMI
<b>Options:</b>	Enclosure heating housing for high temperature applications Mounting bracket

## Transmitter Range

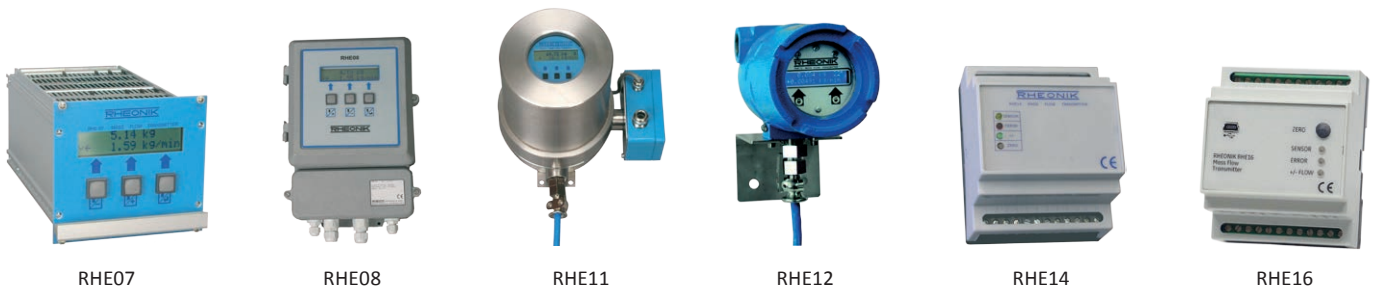

Any Rheonik Mass Flow Transmitter model can be combined with an RHM03 to provide an overall mass flow measurement system to suit any requirement. Rheonik Coriolis transmitters are designed for process, industrial and OEM applications. Together they offer a tremendous range of options for system designers and end users alike.

## RHM03 Measurement Performance

Standard Calibration		
Flow Rate		Uncertainty
kg/min	lb/min	in % of reading
5.00	11.02	0.20
3.00	6.61	0.20
1.00	2.20	0.20
0.25	0.55	0.20
0.10	0.22	0.20

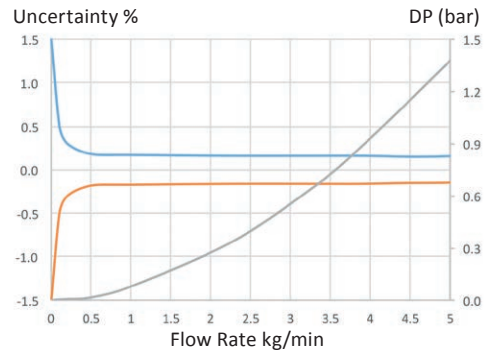

Goldline Calibration*		
Flow Rate		Uncertainty
kg/min	lb/min	in % of reading
5.00	11.02	0.10
3.00	6.61	0.10
1.00	2.20	0.10
0.50	1.10	0.10
0.25	0.55	0.12

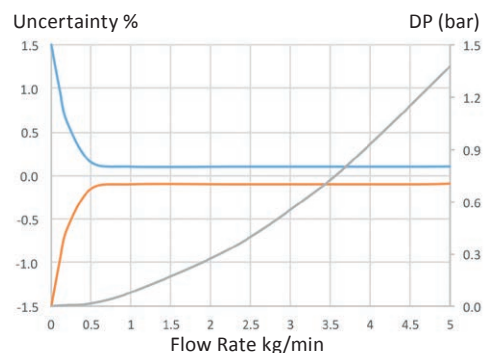

Low Flow Calibration*		
Flow Rate		Uncertainty
kg/min	lb/min	in % of reading
2.00	4.41	0.20
1.00	2.20	0.20
0.50	1.10	0.20
0.10	0.22	0.20
0.08	0.17	0.60

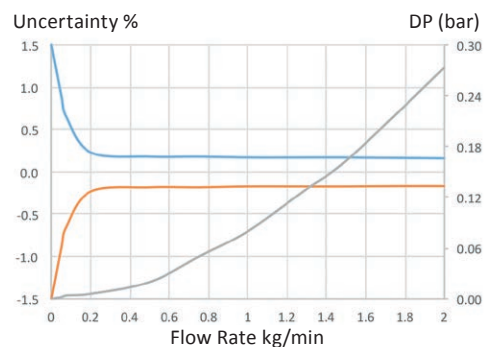

\*Goldline and Low Flow Calibration is not available with all configurations of the RHM03. Please check with factory.

Mass Flow Calibration Options	
<b>A</b>	50:1 Standard Calibration – 0.5% Uncertainty between 5 and 0.1 kg/min
<b>B</b>	20:1 Standard Calibration – 0.2% Uncertainty between 5 and 0.25 kg/min
<b>C</b>	1:20 Calibration – 0.2% Uncertainty between 0.1 and 2 kg/min
<b>G</b>	20:1 Goldline Calibration – 0.12% Uncertainty between 5 and 0.25 kg/min
<b>P</b>	10:1 Goldline Calibration – 0.10% Uncertainty between 5 and 0.5 kg/min
<b>1</b>	Low Flow Calibration – 0.2% Uncertainty between 0.1 and 2 kg/min, 0.6% between 0.075 and 0.1 kg/min

- *Uncertainty of reading (incl. zero drift) stated at reference condition of: H<sub>2</sub>O, 18-24°C (66-76°F), 1-3 bar (15-45 psi) when installed according to field manual*
- *Pressure drop indications are based upon H<sub>2</sub>O flowing in a meter with MO material, P1 pressure rating and PMO (parallel measuring tubes with manifold block) construction*
- *Serial path versions offer the same accuracy performance at half the flow (Nominal max. flow range of serial versions = 2.5 kg/min). Pressure drop will be greater*
- *For customized calibration range and/or uncertainty levels, please consult factory*

**Flow Measurement Repeatability**    **Temperature**  
 Standard ± 0.1% of rate                      Better than ± 1°C  
 Goldline ± 0.05% of rate

## RHM03 Pressure Ratings

The maximum pressure ( $P_{max}$ ) of a sensor is determined by its lowest rated part. The lowest rated part can be either the measuring tube ( $P_{max}$  indicated below), the construction type ( $P_{max}$  indicated in the Part Number Code section, last page) or the process connection (for  $P_{max}$  see published standards or manufacturer information).

## RHM03 Measurement Tube Pressure Ratings

Pressure Code	Material Code	Material	$P_{max}$				
			bar	psi		°C	°F
P1 (ultralow pressure drop)	M0 (std.)	1.4539 (904L) UNS N08904	175	2538	@	50	122
			150	2176	@	120	248
			120	1740	@	210	410
			100	1450	@	350	662
PA (low pressure drop)	M0 (std.)	1.4539 (904L) UNS N08904	270	3916	@	50	122
			200	2901	@	120	248
			160	2321	@	210	410
			150	2176	@	350	662
PA	M1*	1.4571 (316Ti) UNS S31635	248	3597	@	50	122
P2 (std.)	M0 (std.)	1.4539 (904L) UNS N08904	372	5395	@	50	122
			300	4351	@	120	248
			250	3626	@	210	410
			200	2901	@	350	662
P2	M3	2.4602 (Alloy C22) UNS N06022	460	6672	@	50	122
			390	5656	@	120	248
			320	4641	@	210	410
			256	3713	@	350	662
P2	M4**	Tantalum UNS R05200	160	2321	@	50	122
			123	1784	@	120	248
			99	1436	@	210	410
P2	10***	1.4410 (Super Duplex) UNS S32750	812	11777	@	50	122
			712	10327	@	120	248
			644	9340	@	210	410
P2	62***	1.4462 (Duplex) UNS S31803	649	9413	@	50	122
			568	8238	@	120	248
			497	7208	@	210	410
PH	HP****	Sandvik HP160	1067	15476	@	20	68
			900	13053	@	50	122
			870	12618	@	120	248

\*Only for T3 temperature range. \*\*Only with T1, TA, T2 temperature range (note max. operating temp. is 150°C) and PF0 construction type (max. ANSI 600/PN100).  
 \*\*\*Only with T1, TA, T2 temperature range (note min. temp. is -40°C) and PF0 construction type. \*\*\*\*Only with construction types PM0, SM0, PH0, SH0, PHH, SHT.

## Other Materials

Additional/custom wetted materials (Inconel, Monel, 304 stainless steel, others) may be possible for chemical compatibility, lower pressure drop, abrasion allowance, other application specific requirements.

Contact factory with specification for assessment and availability.

## RHM03 Mechanical Construction

**PM0/SM0:** Serial or parallel measuring tubes with flange connection and removable manifold with PTFE seals

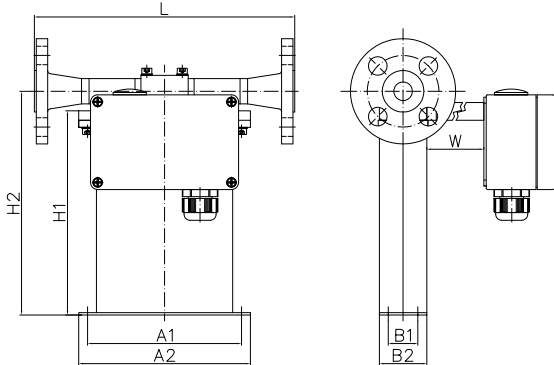

H1 = 173 mm (6.79 in)  
H2 = 189 mm (7.44 in)

Process Connection	Face to face length (L)		Order Code
	mm	in	
ANSI ½" 150# RF	220	8.66	A1
ANSI ½" 300# RF	220	8.66	A2
ANSI ½" 600# RF	220	8.66	A3
ANSI ½" 1500# RF	300	11.81	A6
ANSI ½" 1500# RTJ	300	11.81	R1
DIN DN15/PN40	220	8.66	D1
DIN DN15/PN100	220	8.66	D2
DIN DN15/PN 160	220	8.66	D3
JIS RF 10k 15A (½")	220	8.66	J1
JIS RF 20k 15A (½")	220	8.66	J2

**PM0/SM0 / PH0/SH0:** Serial or parallel measuring tubes with female thread connection and removable manifold with PTFE seals

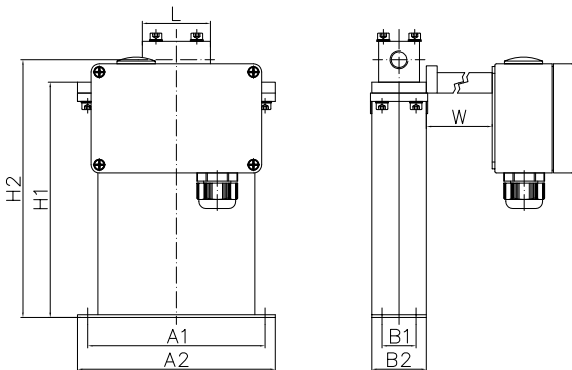

PM0/SM0                      PH0/SH0 (high pressure manifold)  
H1 = 173 mm (6.79 in)    H1 = 184 mm (7.24 in)  
H2 = 189 mm (7.44 in)    H2 = 204 mm (8.03 in)

Process Connection	Face to face length (L)		Order Code
	mm	in	
<b>PM0/SM0</b>			
Female Thread G ¼"	50	1.97	G1
Female Thread ¼" NPT	50	1.97	N1
<b>PH0/SH0</b>			
Female Thread G ¼"	70	2.76	G1
Female Thread ¼" NPT	70	2.76	N1
Autoclave ⅜" MP (⅝"-18 UNF female thread)	70	2.76	P2

**PHH:** Parallel measuring tubes with MP Autoclave connection and removable very high pressure manifold with PTFE seals

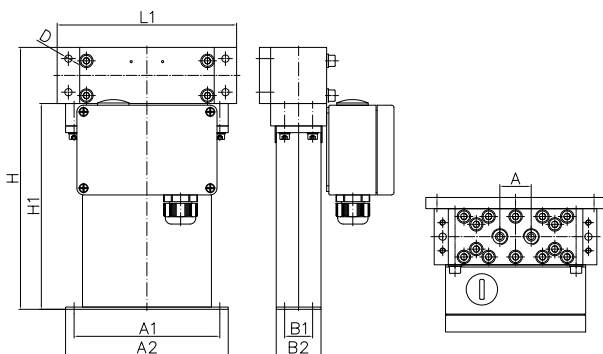

H1 = 184 mm (7.24 in)    D = Ø6.5 mm (0.26 in)  
A = 28 mm (1.10 in)      L1 = 160 mm (6.30 in)

Process Connection	Overall height (H)		Order Code
	mm	in	
Autoclave ⅜" MP (⅝"-18 UNF female thread)	234	9.21	P2

The sensor is manufactured with two internal measurement tubes arranged side by side. In parallel or dual path sensors, these tubes are connected in parallel and the flowing fluid is split equally between them. In serial or single path sensors, the tubes are connected end to end creating a single path through which all fluid flows. For customization of face to face length and/or special fittings other than the ones listed on this page, please consult factory. *Note that larger diameter flange process connections are always possible.*

### Common Dimensions

A1 = 130 mm (5.12 in)    A2 = 145 mm (5.71 in)    B1 = 25 mm (0.98 in)    B2 = 40 mm (1.57 in)  
W: temp. range T1, TA = 0 mm (0 in), temp. range T2 = 100 mm (3.94 in)  
Electrical box: std. = 125 x 80 x 58 mm (4.92 x 3.15 x 2.28 in), RHE16 compact = 120 x 120 x 80 mm (4.72 x 4.72 x 3.15 in)

For weights and packaging dimensions please see last page of the Mechanical Construction section.

## RHM03 Mechanical Construction

**PFO:** Seal-less parallel measuring tube construction with flange connections

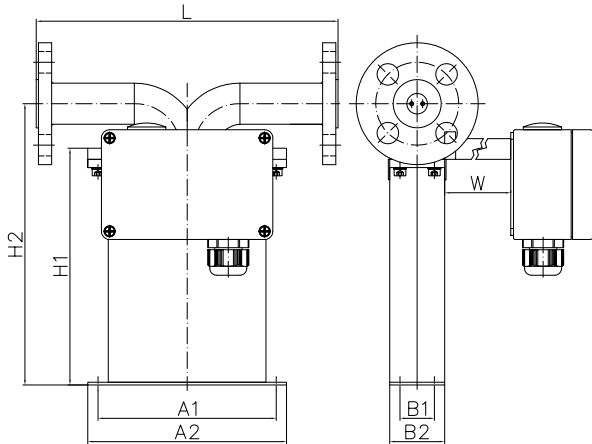

Process Connection	Face to face length (L)		Order Code
	mm	in	
ANSI ½" 150# RF	220	8.66	A1
ANSI ½" 300# RF	220	8.66	A2
ANSI ½" 600# RF	220	8.66	A3
ANSI ½" 1500# RF	300	11.81	A6
ANSI ½" 2500# RF	300	11.81	A8
ANSI ½" 1500# RTJ	300	11.81	R1
ANSI ½" 2500# RTJ	300	11.81	R2
DIN DN15/PN40	220	8.66	D1
DIN DN15/PN100	220	8.66	D2
DIN DN15/PN 160	220	8.66	D3
DIN DN25/PN 40	260	10.24	D4
JIS RF 10k 15A (½")	220	8.66	J1
JIS RF 20k 15A (½")	220	8.66	J2
Grayloc 1" GR4 Hub	300	11.81	H3

**PFT:** Seal-less parallel measuring tube construction with thread and compression fitting connections

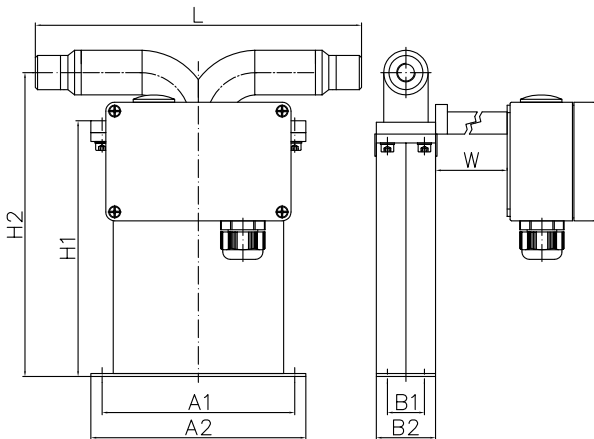

Process Connection	Face to face length (L)		Order Code
	mm	in	
Female Thread G ¼"	220	8.66	G1
Female Thread ¼" NPT	220	8.66	N1
Swagelok ¼" tube compression fitting (SS-400-1-4W)	300	11.81	W1

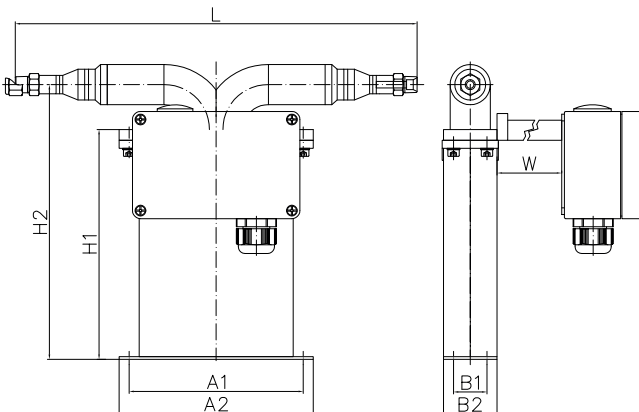

The sensor is manufactured with two internal measurement tubes arranged side by side. In parallel or dual path sensors, these tubes are connected in parallel and the flowing fluid is split equally between them. For customization of face to face length and/or special fittings other than the ones listed on this page, please consult factory. *Note that larger diameter flange process connections are always possible.*

### Common Dimensions

A1 = 130 mm (5.12 in)    A2 = 145 mm (5.71 in)    B1 = 25 mm (0.98 in)    B2 = 40 mm (1.57 in)    H1 = 173 mm (6.79 in)    H2 = 205 mm (8.07 in)

W: temp. range T1, TA = 0 mm (0 in), temp. range T2, T3, T4 = 100 mm (3.94 in)

Electrical box: std. = 125 x 80 x 58 mm (4.92 x 3.15 x 2.28 in), RHE16 compact = 120 x 120 x 80 mm (4.72 x 4.72 x 3.15 in)

For weights and packaging dimensions please see last page of the Mechanical Construction section.

## RHM03 Mechanical Construction

**SFO:** Seal-less serial measuring tube construction with sanitary connections\*

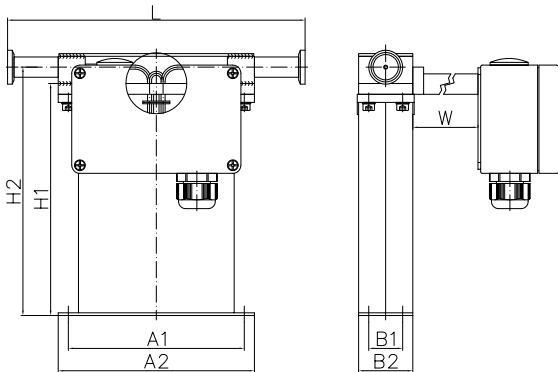

H2 = 184 mm (7.22 in)

Process Connection	Face to face length (L)		Order Code
	mm	in	
Sanitary ½" Triclamp, DIN 32676	220	8.66	S1*
Sanitary NW10, DIN 11851	220	8.66	S2*

The sensor is manufactured with two internal measurement tubes arranged side by side. In serial or single path sensors, the tubes are connected end to end creating a single path through which all fluid flows. For customization of face to face length and/or special fittings other than the ones listed on this page, please consult factory.  
*Note that larger diameter flange process connections are always possible.*

**SFO:** Seal-less serial measuring tube construction with flange connections

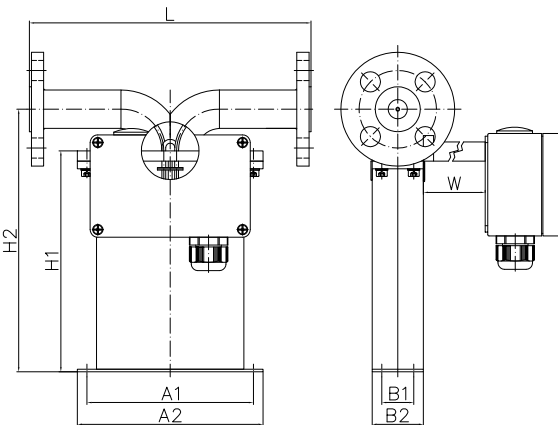

H2 = 205 mm (8.07 in)

Process Connection	Face to face length (L)		Order Code
	mm	in	
ANSI ½" 150# RF	220	8.66	A1
ANSI ½" 300# RF	220	8.66	A2
ANSI ½" 600# RF	220	8.66	A3
ANSI ½" 1500# RF	300	11.81	A6
ANSI ½" 1500# RTJ	300	11.81	R1
DIN DN15/PN40	220	8.66	D1
DIN DN15/PN100	220	8.66	D2
DIN DN15/PN 160	220	8.66	D3
DIN DN25/PN 40	260	10.24	D4
DIN DN25/PN 160	260	10.24	D5
JIS RF 10k 15A (½")	220	8.66	J1
JIS RF 20k 15A (½")	220	8.66	J2

**SFT/SHT:** Seal-less serial tube construction with thread and compression fitting connections

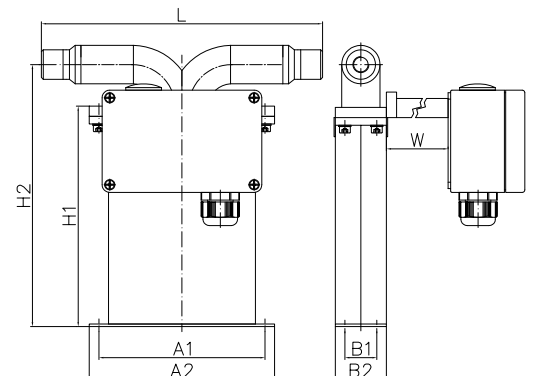

Process Connection	Face to face length (L)		Order Code
	mm	in	
<b>SFT</b>			
Female Thread G ¼"	220	8.66	G1
Female Thread ¼" NPT	220	8.66	N1
Swagelok ¼" tube compression fitting (SS-400-1-4W)	300	11.81	W1
<b>SHT</b>			
Autoclave ⅜" MP (⅜"-18 UNF female thread)	220	8.66	P2
Female Thread ¼" NPT	220	8.66	N1

### Common Dimensions

A1 = 130 mm (5.12 in)    A2 = 145 mm (5.71 in)    B1 = 25 mm (0.98 in)    B2 = 40 mm (1.57 in)    H1 = 173 mm (6.79 in)  
 W: temp. range T1, TA = 0 mm (3.94 in), temp. range T2, T3, T4 = 100 mm (3.94 in)  
 Electrical box: std. = 125 x 80 x 58 mm (4.92 x 3.15 x 2.28 in), RHE16 compact = 120 x 120 x 80 mm (4.72 x 4.72 x 3.15 in)

\*P<sub>max</sub> for sanitary fittings is 40 bar (580 psi) @120°C (248°F).

### Weights and Shipping Dimensions

Typical weight for standard manifold construction (PM0/SM0) sensor with female threads: approx. 2.5 kg (5.5 lb).  
 Typical weight for standard seal-less construction (PF0/SFO) sensor with 150# flanges: approx. 3.5 kg (7.7 lb).  
 RHM03 sensors typically ship in a carton approx. 60 x 41 x 32 cm (24 x 16 x 13 in) complete with transmitter and cable.  
 Typical gross shipping weight example: RHM03 seal-less construction sensor with 150# flanges c/w RHE08 transmitter approx. 10 kg (22 lb).

